



# Recycled Water USER MANUAL

DEVELOPED BY:  
Los Angeles County  
Recycled Water Advisory Committee

2 0 0 5

## **“On-Site” Supervisor Do's and Don'ts**

### **Do's**

- Install and maintain signs at all points of entry (pedestrian and vehicular)
- Install and maintain labels and tags on recycled and potable water systems
- Operate irrigation system:
  - Between 10 p.m.–6 a.m. if automatically controlled (unless other restrictions apply)
  - At other times if manually controlled and supervised (someone present) to make sure the recycled water doesn't come in contact with the public
  - At any time if use site is restricted to the general public
- Use quick couplers instead of hose bibbs
- Contact “provider” if any water system (potable or recycled) modifications are anticipated
- Immediately contact water utility and/or recycled water producer if any of the following has occurred:
  - A recycled water line break, spill or off-site discharge of recycled water
  - A violation of water recycling requirements
  - A cross-connection between the recycled and potable water systems
- Educate/train site workers on safe use and restrictions of recycled water
- Keep records and as-built drawings up-to-date and accessible
- Assist and cooperate during Periodic Visual Inspections
- Assist and cooperate during Periodic Cross-Connection Testing

### **Don'ts**

- Don't drink recycled water
- Don't use recycled water to wash hands or any other part of body
- Don't remove recycled water identification signs, tags or labels
- Don't cross-connect two dissimilar water systems (recycled to potable)
- Don't allow recycled water to contact drinking fountains or eating areas
- Don't allow recycled water to pond or puddle
- Don't allow recycled water to runoff the use site property by either overspray or overwatering
- Don't use recycled water on an unapproved site
- Don't put hose bibbs on recycled water systems (unless public access is restricted)
- Don't use the same equipment on both recycled water and domestic water systems (for example, quick couplers, tools, etc.)
- Don't modify any water system without prior approval of provider and/or Health Department

## TABLE OF CONTENTS

SECTION	PAGE
FOREWORD.....	1
INTRODUCTION .....	2
PURPOSE.....	2
WHAT IS RECYCLED WATER?.....	3
WHAT ARE “DUAL SOURCE” SITES?.....	3
BENEFITS OF RECYCLED WATER IRRIGATION .....	4
ARE THERE DISADVANTAGES TO USING RECYCLED WATER? .....	5
NEED FOR REGULATIONS .....	5
USER'S SUMMARY.....	6
SECTION A GENERAL PROVISIONS.....	7
REGULATORY AUTHORITY .....	7
SYSTEM RESPONSIBILITY .....	7
USER AGREEMENT AND PERMITS .....	8
RATE AND FEE SCHEDULE .....	8
PROTECTION OF PUBLIC HEALTH .....	8
AUTHORIZED USES .....	8
APPROVED USE AREAS.....	8
LIABILITY.....	8
WATER SUPPLY CONTINGENCY.....	9
SECTION B DESIGN & CONSTRUCTION.....	10
DESIGN APPROVAL.....	10
CONSTRUCTION.....	10
RECYCLED WATER DELIVERY SYSTEM OPERATION.....	10
Backup Water Source .....	11
FIRE PROTECTION SYSTEMS .....	11
PROTECTION OF GROUNDWATER .....	11
SERVICE STARTUP.....	11
SECTION C OPERATION & MAINTENANCE .....	13
GENERAL.....	13
CONDITIONS OF SERVICE .....	13
Runoff Conditions.....	13
Ponding Conditions.....	13
Windblown Spray Conditions.....	13
Unapproved Uses .....	13
Use in Unapproved Areas .....	13
Cross-Connections .....	13
DESIGNATION OF SITE SUPERVISOR .....	14
PERSONNEL TRAINING .....	14
PERIODS OF OPERATION .....	15
HOSE BIBBS .....	16
DRINKING FOUNTAINS .....	16

EQUIPMENT CLEANING .....	16
MODIFICATIONS .....	16
MAINTENANCE .....	17
PERIODIC SITE INSPECTIONS .....	17
EMERGENCY PROCEDURES.....	18
Emergency Modifications.....	18
Unauthorized Discharge.....	18
Contamination of Drinking Water .....	18
VIOLATIONS .....	18
NOTIFICATION .....	18
CORRECTIVE ACTION .....	19
ENFORCEMENT .....	19
CAUSES FOR TERMINATION OF SERVICE.....	19
<b>SECTION D MARKING &amp; EQUIPMENT.....</b>	<b>20</b>
GENERAL.....	20
PIPING, BELOW-GRADE .....	20
Identification of Recycled Water Lines .....	20
Identification of Potable Water Lines .....	21
Identification of Non-Potable Water Lines.....	21
Identification of Existing Below-Grade Water Lines .....	21
PIPING, ETC., ABOVE-GRADE .....	21
VALVES.....	22
Quick Coupling Valves.....	22
Gate Valves.....	22
Remote Control Valves.....	22
SPRINKLER HEADS .....	22
SYSTEM CONTROL DEVICES .....	23
STORAGE TANKS & IMPOUNDMENTS .....	23
OTHER DEVICES .....	23
VEHICLE IDENTIFICATION .....	23
POSTING APPROVED USE AREA .....	24
<b>SECTION E CROSS-CONNECTION CONTROL.....</b>	<b>26</b>
PROTECTION OF POTABLE WATER SYSTEMS .....	26
INITIAL CROSS-CONNECTION TEST .....	26
FINAL CROSS-CONNECTION TEST .....	26
PERIODIC CROSS-CONNECTION TESTING (PCCT).....	27
EMERGENCY CROSS-CONNECTION RESPONSE PLAN .....	27
<b>SECTION F REUSE SITE PRESSURE-TESTING PROCEDURE .....</b>	<b>29</b>
<b>SECTION G SAMPLE FORMS AND SITE SPECIFIC DETAILS.....</b>	<b>30</b>
SUMMARY OF STEPS TO OBTAIN RECYCLED WATER .....	30
<b>SECTION F LOCAL GOVERNING AGENCIES.....</b>	<b>36</b>
<b>SECTION G DEFINITIONS .....</b>	<b>37</b>
<b>SECTION H TIPS FOR SUCCESSFUL USAGE.....</b>	<b>41</b>
SALT LEVELS.....	41
Type of Plants .....	41

Soil Types .....	41
Irrigation Schedule.....	41
NUTRIENTS .....	42
Fertilizer Value .....	42
Ornamental Lakes .....	42
Increased Mowing.....	43

## FOREWORD

The Recycled Water Urban Irrigation User's Manual (Manual) has been prepared to convey the general rules, regulations and guidelines regarding the safe introduction and use of recycled water for landscape irrigation in Los Angeles County and other areas in the State of California. This document was prepared by the *Los Angeles County Recycled Water Advisory Committee* (LACRWAC, a local chapter of the California Section of the WaterReuse Association), which is comprised of water utilities, regulatory interests, and other entities interested in the safe introduction and use of recycled water. At the time of this publication, LACRWAC included:

### Regulatory Agencies:

- State of California Department of Health Services
- County of Los Angeles Department of Health Services
- Los Angeles Regional Water Quality Control Board

### Water and Wastewater Utilities:

- Castaic Lake Water Agency
- Central Basin Municipal Water District
- City of Burbank
- City of Glendale
- City of Long Beach
- City of Pasadena
- County Sanitation Districts of Los Angeles County
- Las Virgenes Municipal Water District
- Los Angeles Department of Water & Power
- Metropolitan Water District of Southern California
- Water Replenishment District of Southern California
- West Basin Municipal Water District
- Upper San Gabriel Valley Municipal Water District

### Other Interested Entities:

- California State Department of Water Resources
- Carollo Engineers
- CH2M HILL
- Tetra Tech, Inc.

***Each recycled water customers' representative ("Site Supervisor") is responsible to read and understand the Manual and any water reclamation requirements applicable to their particular site. Questions about the use of recycled water or the Manual should be directed to the "Recycled Water Agency" that serves the customer.***

## INTRODUCTION

### PURPOSE

The purpose of this Manual is to provide the recycled water “User” and “Site Supervisor” a resource for the day-to-day operation and control of that system, in order to protect the health and welfare of the personnel involved with its use as well as the general public, and to protect the quality of local water resources. Recycled water is an important resource for the State of California, and its use for nonpotable applications is, in many cases, mandated by State law. This Manual provides necessary information to meet existing regulations for the operation of the User’s recycled water system.

Every effort has been made to ensure that this Manual is in compliance with, and is not intended to supersede, existing codes, laws, statutes and regulations of the State of California, Regulatory Agencies and local governing bodies, concerning the currently approved use of recycled water. This Manual is also not intended to supersede the American Water Works Association (AWWA) California-Nevada Section’s Guidelines for Distribution of Nonpotable Water or Guidelines for the On-site Retrofit of Facilities Using Disinfected Tertiary Recycled Water.

Since legal and regulatory requirements can change without the express approval or knowledge of the Recycled Water Agency, the Recycled Water Agency assumes no liability for errors in this Manual. It’s the responsibility of the User to check with its Recycled Water Agency before initiating any operational or physical changes to the use site’s system.

This Manual is organized in the following manner:

- ☞ The *User’s Summary* provides a brief commentary on major topics and indicates a page number to find additional information.
- ☞ *General Provisions* covers the basic administrative requirements including authorities, responsibilities and liabilities.
- ☞ *Design and Construction* covers the considerations needed when an on-site recycled water system is first installed or modified.
- ☞ *Operation and Maintenance* covers the basic conditions for service contained in the State of California’s “Water Recycling Criteria”.
- ☞ *Marking and Equipment* gives the basic requirements for marking the water systems and signing the use area.
- ☞ *Cross-connection Controls* and *Pressure Testing Procedure* outline the requirements for protecting the potable water system and keeping it separate from the recycled water system.
- ☞ *Sample Forms and Site-Specific Details* provides a summary of steps to obtain recycled water, templates of sample forms to help with inspections and a location for information specific to the use-site.
- ☞ *Local Governing Agencies* provides the names, addresses and phone numbers of agencies responsible for the regulatory administration of water recycling activities.
- ☞ *Definitions* are included for terms used within the Manual.

## WHAT IS RECYCLED WATER?

“Recycled water,” (also called “reclaimed water”) as used in this Manual and defined in Title 22, Chapter 3 of the California Code of Regulations, refers to tertiary-treated water produced from the three-stage treatment of municipal wastewater (see box, right). (Although secondary-treated effluent may also be reused, its applications are limited and subject to much greater restrictions, and it will not be addressed in this Manual.) The facilities that produce recycled water are known as Water Recycling (or Reclamation) Plants that are owned and operated by “Recycled Water Producers.” The recycled water produced by these plants is delivered to users through distribution systems owned and operated by “Recycled Water Agencies.” Recycled Water Producers and Agencies can be one and the same entity.

Recycled water is virtually colorless and odorless, and is allowable for full-body human contact but **not** for direct human consumption. The sensible use of recycled water affords an excellent choice for essentially all non-potable applications. Properly managed, recycled water is safe to use.

## WHAT ARE “DUAL SOURCE” SITES?

“Dual source” sites are reuse sites where both potable (domestic or drinking) water and recycled water are present. Dual sources might be necessary on sites where water is normally available for public use. For example, a cemetery may use recycled water for irrigation, but would need a separate potable system with hose bibbs to allow visitors to fill flower urns. “Dual plumbed sites” is a separate term which refers specifically to either buildings that have both recycled and potable water serving

### The Recycled Water Treatment Process

- ◆ **Primary Treatment** removes 70 to 85 percent of the organic and inorganic solids that either settle out or float to the top.
- ◆ **Secondary Treatment** mixes the remaining suspended waste solids with microorganisms and air. The micro-organisms convert the waste solids to biomass that settles out.
- ◆ **Tertiary Treatment** filters out most of the remaining solids through a granular media (for example, sand or anthracite coal) or a membrane, with the final product water being disinfected with chlorine or ultraviolet light to kill off bacteria, virus and other microorganisms.

interior fixtures, or individual residences that use recycled water for outside irrigation, and is dealt with later under *Periodic Cross Connection Testing* (page 27). The public must not be allowed access to the recycled water system (such as from hose bibbs). Water quality needs at the use site might also call for two water sources. For example, golf courses may elect to use a potable water supply to irrigate the greens and use recycled water on the fairways.

(**Note:** The potable water used for this purpose is referred to as “non-potable irrigation water” after it has passed through the irrigation system backflow preventer. These water lines are to be used only for irrigation and must not be connected to restrooms, drinking fountains, food service areas, etc.)



On sites with dual sources, the potable supply must be protected with an approved backflow prevention device.

**Cross-connections between the recycled water system and the potable water system are strictly prohibited.**

## **BENEFITS OF RECYCLED WATER IRRIGATION**

As population growth increases the demand for potable water and the reliability of imported water supplies decreases, the future availability of potable water for irrigation is questionable. Also, the costs of potable water supplies continue to climb, making recycled water more attractive as an alternative water supply.

The amount of recycled water available is generally not affected by drought, meaning customers don't risk losing expensive landscaping due to water shortages and potential mandatory rationing.

Tertiary-treated recycled water can be used for virtually all non-potable applications (see box, right).

Recycled water may also contain an appreciable nutrient content, such as nitrogen, potassium, calcium, magnesium, sulfur, and other macro and micronutrients, which may provide some level of fertilization during the irrigation process. A full recycled water quality analysis can be obtained from the local Recycled Water Agency.

Irrigating with recycled water is making use of a valuable resource that would otherwise be disposed.

### **TITLE 22 USES FOR TERTIARY-TREATED WATER**

**Urban Landscape** – Parks and playgrounds, schoolyards, unrestricted access golf courses, residential landscaping, freeway and roadway landscaping, cemeteries, ornamental nurseries, sod farms.

**Agriculture** – Food crops for human consumption, orchards, vineyards, fodder, fiber and seed crops, non-fruit bearing trees, pasture for milking animals, water supply for livestock.

**Impoundments** – Restricted and unrestricted (full-body contact) recreational impoundments, decorative lakes and fountains, fish hatcheries.

**Industrial** – Industrial processes (e.g., paper manufacturing, carpet and textile dyeing, boiler feed), cooling towers and air conditioning, non-residential toilet, urinal and floor drains, structural and non-structural fire fighting, commercial laundries, commercial car washes, concrete mixing, construction (dust control, soil compaction, backfill consolidation around pipelines, including potable), street and sidewalk cleaning, flushing sanitary sewers, snow making.

## ARE THERE DISADVANTAGES TO USING RECYCLED WATER?

Recycled water must be used responsibly within established guidelines, regulations and permit requirements. Because of its origins and the level of treatment provided, recycled water is not suitable for direct human consumption. Unlike potable water, recycled water can only be used for approved uses, at approved locations, under the provisions of established regulations, agreements or permits. At the time of this writing, there have been no known cases of illness in the State of California due to the proper use of recycled water (according to the State DHS).

In very rare occasions, there may be temporary interruptions of recycled water deliveries, as there are in any utility. Such instances are generally short in duration.

## NEED FOR REGULATIONS

Regulations make the use of recycled water possible. Regulations ensure consistent, reliable water quality while being fully protective of the public health. California Code of Regulations Titles 22 and 17 are the two sets of State DHS regulations that accomplish this. Title 22 establishes the requirements for recycled water treatment, quality and allowable use. Title 17 establishes the requirements for backflow protection of the potable water supply.

Copies of these regulations may be obtained from your Recycled Water Agency.

## USER'S SUMMARY

Recycled water is a safe and effective resource for nonpotable use. Properly managed recycled water has a very limited health risk, if any. To help in the proper management of recycled water, the State of California, the local city or county Health Department and the Recycled Water Agency have developed rules and regulations for the safe use of recycled water. These rules and regulations are in place to insure that the User, its Site Supervisor and employees, and the public are protected from any health risk (real or perceived) that might be associated with the use of recycled water.

- ☞ Because recycled water is not suited for human consumption, every effort must be made to prevent the user's recycled water system from being cross-connected with the potable (drinking) water system.
- ☞ Plans must be carefully reviewed to ensure against cross-connections and that proper equipment is to be installed (Design Approval, page 10).
- ☞ The recycled water system must be operated under the authority of a "User's Agreement" (page 8) that outlines any special considerations or requirements for the particular use site.
- ☞ The User must designate a "Site Supervisor" (page 14) who is responsible for managing the on-site water system. The Site Supervisor ensures the system is operated within the established guidelines and is properly maintained (Maintenance, page 17).
- ☞ In cooperation with the User, the Recycled Water Agency and/or Producer will make regular inspections of the site (Periodic Site Inspections, page 17).
- ☞ The User must instruct all persons using recycled water of its proper use and precautions (Personnel Training, page 14).
- ☞ All piping and points of connection must be labeled with "Recycled Water -- Do Not Drink" (Marking and Equipment, page 21) and the universal "Do Not Drink" symbol (page 25).
- ☞ All recycled water use areas accessible to the public must be posted with signs visible to the public and must include the statement "Recycled Water -- Do Not Drink" (page 24) and the "Do Not Drink" symbol (page 25).
- ☞ An initial cross-connection test must be conducted to determine if there are any unknown connections between existing irrigation and potable piping prior to construction of retrofit work (Initial Cross-Connection Test, page 26).
- ☞ Prior to connection with the recycled water distribution system, a final cross-connection test must be performed to verify that construction or retrofit work was performed correctly (Final Cross-Connection Test, page 26).
- ☞ In the event of a cross-connection incident, the User must implement an emergency response plan (page 27).

## SECTION A GENERAL PROVISIONS

### REGULATORY AUTHORITY

Rules and regulations for the end use of recycled water are established and/or enforced by the California Regional Water Quality Control Board (Regional Board), the State DHS and the local city or county Health Department. These rules and regulations are typically contained in a permit from the Regional Board issued to the Recycled Water Agency and/Producer. All facilities using recycled water must be designed and operated to meet the standards of the local governing codes, rules and regulations.

Various regulations for recycled water use may be outlined in the Recycled Water Agency's Recycled Water Ordinance. However, if recycled water service is provided by an Investor Owned Utility, the various regulations for recycled water use are outlined in the Recycled Water Agency's Tariff Schedules as approved by the California Public Utilities Commission.

From time to time there may be amendments to existing regulations. These amendments may be made without the knowledge or consent of the User or the Recycled Water Agency. These amendments will be enforced upon their effective date. The Recycled Water Agency will make every effort to make sure the User is made aware of these changes when they occur.

### SYSTEM RESPONSIBILITY

The Recycled Water Agency is responsible for the operation and maintenance of its recycled water distribution system up to the point of connection to the User. However, it's the responsibility of the User to maintain

its recycled water system downstream of the point of connection (usually the meter) with the Recycled Water Agency's distribution system. The User is responsible for ensuring that the recycled water is used on its site according to all the rules and regulations regarding such use. Specifically, the User is responsible for the following:

- ☞ Maintaining the use site's recycled water system.
- ☞ Ensuring that all materials used during the design, construction and maintenance of the system are approved or recommended for recycled water use by the AWWA California-Nevada Section's Guidelines for the On-site Retrofit of Facilities Using Disinfected Tertiary Recycled Water.
- ☞ Obtaining all permits and payment of all fees required for the establishment, operation and maintenance of the User's recycled water system.<sup>1</sup>
- ☞ Reporting all violations and emergencies to the required local governing agencies. A listing of these agencies is provided in Section H.
- ☞ Obtaining prior authorization from the Recycled Water Agency and any required regulatory agency before making any modifications to the approved recycled water system (or the potable water system if it's in close proximity to the recycled system).

---

<sup>1</sup> Permitting and/or fee assistance may be available from the Recycled Water Agency.

## USER AGREEMENT AND PERMITS

A potential User must complete all of the Recycled Water Agency's requirements (for example, permit application) prior to the issuance of a User Agreement. (**Note:** "User Agreement" is the term used to describe any agreement, contract, permit, ordinance, memorandum of understanding or other such document used by the Recycled Water Agency to present the terms and conditions for the use of recycled water by a User.) The Recycled Water Agency reserves the right to alter, on a case-by-case basis, the User Agreement.

## RATE AND FEE SCHEDULE

If recycled water is provided by a public entity, such as a water district or municipality, all rates and fees concerning recycled water service will be established and fixed by the Recycled Water Agency.

If recycled water is provided by an Investor Owned Utility, all rates and fees concerning recycled water service shall be established and fixed by the California Public Utilities Commission.

## PROTECTION OF PUBLIC HEALTH

The Recycled Water Agency reserves the right to take any action necessary with respect to the operation of the User's on-site recycled water system in order to safeguard the public health.

## AUTHORIZED USES

The use of recycled water is limited to those uses approved by the Regional Board or the State DHS. Any other use of recycled water is prohibited without the prior approval, on a case-by-case basis, of the Recycled Water

Agency and the appropriate Regulatory Agencies.

## APPROVED USE AREAS

Recycled water may only be used in areas approved by the Recycled Water Agency, following the User's completion of the Recycled Water Agency's application procedure and its meeting all of the requirements of the applicable Regulatory Agencies.

A User may **never** supply recycled water to another owner's adjoining property or to the property of the same User across a street or alley without the prior written approval of the Recycled Water Agency. The User may not give or sell recycled water to another party. Should the property become subdivided, the service will be considered as belonging to the parcel it enters directly. If such a subdivision occurs, or property ownership is transferred, the Recycled Water Agency must be notified.

In any case, recycled water lines are not permitted to cross lot lines. All recycled water delivered to any site must pass through a recycled water meter.

## LIABILITY

The User is responsible for the operation and maintenance of the recycled water system downstream of the Recycled Water Agency's point of connection with the User, unless such responsibility is clearly outlined in the User Agreement/Permit (*Enforcement*, page 19).

The Recycled Water Agency shall not be liable for any water damage or other damage caused by the User due to defective or broken plumbing or faulty service, nor shall the Recycled Water Agency be liable for

damage caused by the User's facilities. This includes changes in the recycled water quality that may occur from sitting in ornamental lakes, storage tanks, pipelines, etc.

The Recycled Water Agency may supply water to the affected area either temporarily or permanently from the potable water system with appropriate backflow protection (*Protection of Potable Water Systems*, page 26 and *Back-up Water Source*, page 11).

### **WATER SUPPLY CONTINGENCY**

If at any time during construction or operation of the recycled water system, real or potential hazards are found, the Recycled Water Agency has the right and the responsibility to immediately suspend, with or without notice, recycled water service in the interest of protecting the public health.

## SECTION B DESIGN & CONSTRUCTION

### DESIGN APPROVAL

Before the construction of any new or major modifications of an existing recycled water system, the design must be submitted for approval by the Recycled Water Agency and the State and local city or county Health Departments. Approval will be contingent upon evidence that all applicable design requirements, rules and regulations for a recycled water system are satisfied. Plans and specifications should include, but not be limited to, the following:

- ☞ A detailed description of the intended use of recycled water, including identification of the area of use.
- ☞ Details showing the complete potable and recycled water systems. For existing facilities converting to recycled water use, details must include the exact location of all existing water piping systems.
- ☞ Details of the intended installation procedures, including as a minimum: backflow preventer locations, color and type of pipe, and additional signage to be used.

### CONSTRUCTION

The appropriate regulatory and recycled water agencies shall have the opportunity to make periodic inspections of the User's site during the construction phase, if applicable, to ensure materials and their installation are according to the approved plans and specifications.

The Recycled Water Agency and/or the State, local city or county Health Department or their authorized agents shall inspect the construction and startup of the

User's recycled water system to ensure that it is in compliance with the approved construction plans, rules and regulations. In addition, representatives of the Regional Board and the State DHS may be involved.

This site inspection is to ensure that proper equipment was used, spray patterns are adjusted to ensure proper coverage without excessive overlapping, and there are no cross-connections with the on-site potable water system. Conditions that might create runoff, ponding or windblown spray, especially on slopes must be corrected. Spray patterns must be checked to make sure that they don't encroach upon public facilities such as drinking fountains or areas outside the approved use area. After correction and verification the system will be allowed to use recycled water.

### RECYCLED WATER DELIVERY SYSTEM OPERATION

The Recycled Water Agency reserves the right to control and schedule the use of recycled water, if control and scheduling are necessary to maintain acceptable working conditions within that agency's recycled water distribution system. The Recycled Water Agency will administer these and other service conditions.

If the available service pressure is higher than the User can accept, the User shall be responsible for providing a pressure-reducing valve downstream of the service meter. If available pressure is lower than what the User needs, the User shall be responsible for providing booster pumping downstream of the meter. Any pumping of recycled water requires the prior written approval of the Recycled Water Agency.

The Recycled Water Agency must ensure that the quality of the recycled water in its distribution system is not compromised by any User. Therefore the Recycled Water Agency may require backflow protection on the User's recycled water system. This backflow protection might be just downstream of the recycled water meter or at specific, on-site location(s) where an activity of the User (such as fertilizer injection) could degrade the quality of the recycled water in the distribution system. If necessary, details will be included in the User Agreement.

Backflow prevention devices must be approved by the Recycled Water Agency and the appropriate regulatory agencies. Devices must be properly maintained, inspected quarterly and tested at least annually. Backflow prevention assemblies, when required on recycled water systems, must be conspicuously labeled. Based on the provisions of the User Agreement, the Recycled Water Agency may provide the required test equipment.

### **Backup Water Source**

If potable water is to be used as a backup source to the recycled water system, it must be done only through an air-gap separation between the two systems and with the prior approval of the State DHS and the local city or county Health Department. The State DHS permits the use of a "swivel-ell" assembly (see sample schematic, next page) that allows for the use site's water supply to be switched between the recycled and potable water systems, if certain stringent requirements are met.

## **FIRE PROTECTION SYSTEMS**

Some recycled water use sites may also have separate potable water service connections for dedicated fire protection systems. Depending on the Class of fire protection system on the reuse site, if the fire service includes piping for delivery systems outside of buildings and the manner of on-site recycled water usage, then either single check valve, double check valve or RP backflow assemblies may be required at the fire supply meter.

Since requirements vary from place to place, the exact requirements will be provided to the User by the Recycled Water Agency, Regulatory Agency and/or the local city or county Health Department.

## **PROTECTION OF GROUNDWATER**

Irrigation with recycled water within 50 feet or impoundment of recycled water within 100 feet of any drinking water reservoir or well is prohibited. Proposed irrigation with recycled water within 50 feet or impounding recycled water within 100 feet of a non-potable water well requires the approval of the appropriate health agency.

## **SERVICE STARTUP**

Following the acceptance of the User's recycled water system by the Recycled Water Agency, the User may request regular service startup. Upon receipt of the startup request, the Recycled Water Agency will notify the appropriate regulatory agencies, and schedule a final inspection. The startup request shall include the appropriate documentation and any payments and/or fees as indicated in the Recycled Water Agency's User Agreement.



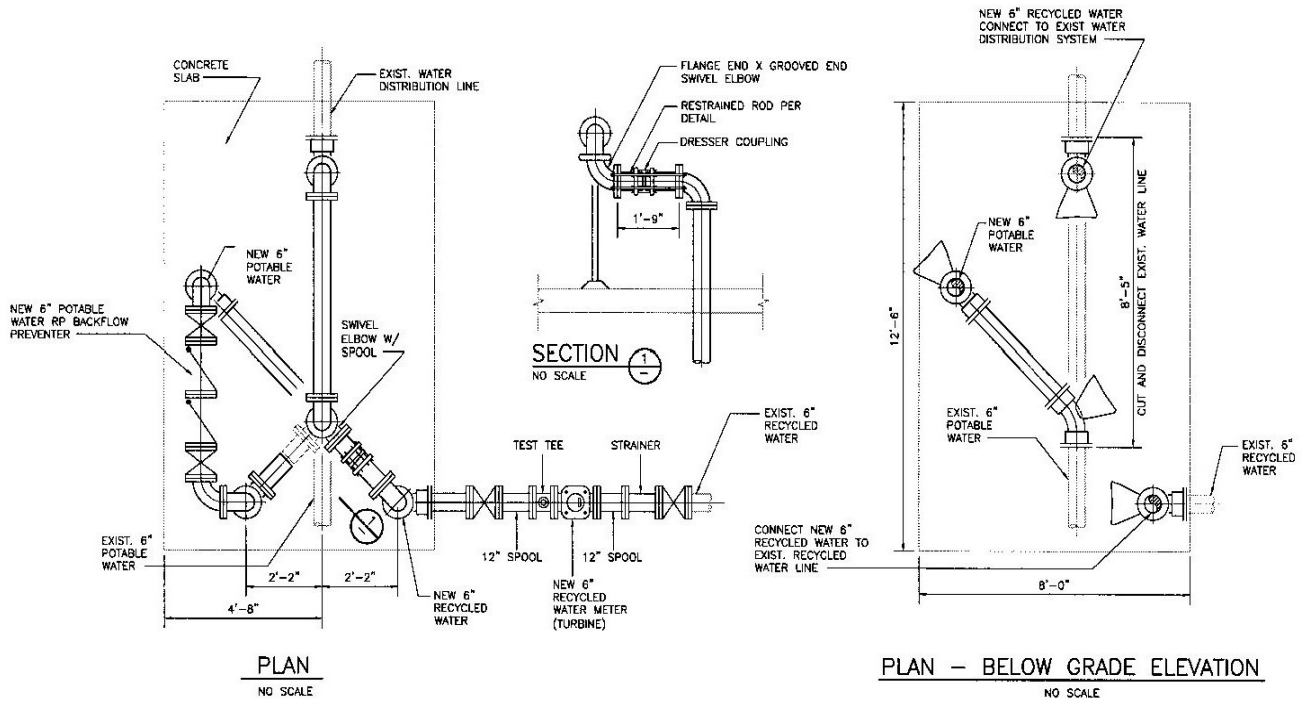

Sample schematic drawing of a "swivel-ell" assembly for a back-up potable water supply.

## SECTION C OPERATION & MAINTENANCE

### GENERAL

Recycled water service will be provided by the Recycled Water Agency only to those Users who have a current User Agreement for such service, unless otherwise determined by the Recycled Water Agency's Governing Board. This recycled water service can be revoked any time at the discretion of the Recycled Water Agency.

Recycled water service must be made available only in accordance with all applicable Federal, state, and local statutes, ordinances, regulations and contracts, and other requirements including the California Water Code, the California Code of Regulations Titles 17 and 22, and requirements and regulations imposed by the Regional Water Quality Control Board, the State DHS, the local city or county Health Department and/or the recycled water Producer. The User must comply with the conditions of any User Agreement issued by the Recycled Water Agency.

**Recycled Water Agencies may not deliver recycled water to Users that do not or will not comply with use site requirements.**

### CONDITIONS OF SERVICE

The User must comply with the following conditions.

#### Runoff Conditions

The irrigation systems must be designed, constructed and operated to minimize to the fullest extent practical runoff outside the approved use area.

#### Ponding Conditions

The irrigation systems must be designed, constructed and operated to minimize to the fullest extent practical ponding within or outside of the approved use area. This does not apply to approved impoundments such as golf course water hazards or decorative lakes.

#### Windblown Spray Conditions

The irrigation systems must be designed, constructed and operated to minimize to the fullest extent practical windblown spray from leaving the approved use area.

#### Unapproved Uses

Use of recycled water for any purposes other than those explicitly described in the Recycled Water Agency's water recycling permit is strictly prohibited.

#### Use in Unapproved Areas

The delivery and use of recycled water for any reason, including approved uses, in areas other than those explicitly approved in the current effective user permit and without the prior approval of the appropriate Regulatory Agencies, is strictly prohibited.

#### Cross-Connections

Cross-connections, as defined by the California Code of Regulations, resulting from the use of recycled water or from the physical presence of a recycled water service, whether by design, construction practice, or system operation, **are strictly prohibited.**

If any cross-connection is discovered, the User shall immediately turn off the system, notify the Recycled Water Agency and implement the *Emergency Cross-Connection Response Plan* (see page 27).

## DESIGNATION OF SITE SUPERVISOR

It is the User's responsibility to provide surveillance and supervision of its on-site recycled water system in a way that assures compliance at all times with current regulations and the recycled water permit requirements. The User shall designate, with notification going to the Recycled Water Agency, a Site Supervisor to be the contact person with the Recycled Water Agency. The following are requirements of the Site Supervisor position:

- ☞ Received training or be able to demonstrate knowledge of the application and maintenance of a recycled water system.
- ☞ Be aware of, and familiar with, this Manual.
- ☞ Be available to the Recycled Water Agency at all times and have the authority to carry out any requirements of the Recycled Water Agency.
- ☞ Be responsible for the installation, operation and maintenance of the recycled and potable water systems, and for the prevention of potential hazards.
- ☞ Ensure that notification signs at the use site are properly installed and maintained, and that all recycled and potable water facilities are properly labeled, tagged or otherwise identified.
- ☞ Be knowledgeable of the provisions contained in Titles 17 and 22 of the California Code of Regulations relating to the safe use of recycled water and maintain accurate records.
- ☞ Ensure that all employees of the use site involved with the use of recycled water are instructed in the safe and responsible use and handling of the recycled water.

- ☞ Immediately inform the Recycled Water Agency of any failures, violations and emergencies that occur involving the recycled or potable water systems.
- ☞ Be familiar with the basic concepts of backflow and cross-connection prevention, system testing, and related emergency procedures, and participate in any cross-connection tests.

The Recycled Water Agency must be notified immediately of any change in personnel for the Site Supervisor position. The Recycled Water Agency will provide the Site Supervisor with periodic inspections of the User's system and report all violations to the appropriate Regulatory Agency according to applicable procedures established by law, code, permit or practice.

## PERSONNEL TRAINING

All new employees must be trained in the proper use of recycled water. Supervisory personnel and the Site Supervisor should be held accountable to ensure that employees are not using recycled water carelessly or improperly. It is the responsibility of the User to train all operations personnel so they are familiar with the use of recycled water. Any training program should include, but not be limited to, the following:

- ☞ Operations personnel must be aware that recycled water, although highly treated, is non-potable. **Recycled water may never be used for human consumption.**
- ☞ Operations personnel must understand that working with recycled water is safe if common sense is used and appropriate regulations are followed.

- ☞ Operations personnel must understand that conditions such as ponding and runoff are not allowed.
- ☞ Good personal hygiene must be followed (for example, washing hands after working with recycled water).
- ☞ Operations personnel must understand that there is never to be a direct connection between the recycled water system and the potable water system.

## PERIODS OF OPERATION

Operation of the User's on-site recycled water system must adhere to the following requirements.

- ☞ Irrigation may only occur during periods of least use of the approved area by the general public. This is usually between the hours of 10 p.m. and 6 a.m.; however, areas where public access is generally prohibited or minimized, such as commercial nurseries and freeway landscaping, may be irrigated at any time.
- ☞ The recycled water system must be operated to prevent overspray or windblown spray into unapproved areas.

- ☞ Even though tertiary-treated recycled water is approved for full-body contact by the State DHS, irrigation of public areas during other times may be performed if the irrigation system is operated manually and is supervised to avoid inadvertently exposing any members of the general public. This provision must be strictly followed.
- ☞ Consideration should be given to allow a reasonable dry-out time before the area is to be used by the public.
- ☞ Automatic control systems are to be used and programmed to prevent ponding and runoff of recycled water.
- ☞ The recycled water system must not be allowed to operate for periods longer than needed to satisfy the landscape water requirements. Recycled water must never be applied at a rate that is greater than the infiltration rate of the soil. Exceptions to this requirement for purposes such as leaching of soil must be specified in the User Agreement.



*Inadvertent public contact with recycled water irrigation spray must always be avoided.*



*Hose bibbs may only be used with recycled water in areas where they cannot be accessed by the general public (such as this commercial nursery), and even those must be properly labeled.*

## HOSE BIBBS

Hose bibbs or other appurtenances that might allow public access to the recycled water system for unapproved use or for cross-connection to the potable water system are strictly prohibited in all areas accessible to the general public. In these areas, only quick-couplers are allowed and must be of a different type than those that may be used on the use site's potable water system (see page 23). Hose bibbs may be used on the recycled water system in areas that do not allow any public access but must be conspicuously labeled ***“RECYCLED WATER -- DO NOT DRINK”*** in both English and Spanish (or any other language determined by the Water Recycling Agency to be in common use in the area), along with the “Do Not Drink”

symbol (page 25). Workers in these areas must be instructed not to drink from these hose bibbs.

## DRINKING FOUNTAINS

Drinking fountains located within the approved use area must be protected from contact with recycled water by direct application through irrigation or other approved use. Lack of protection, whether by design, construction practice or system operation, is strictly prohibited.



*The pattern on the walls indicates that this drinking fountain is being sprayed by the irrigation water. If recycled water is to be used, then the spray pattern must be altered or the drinking fountain somehow shielded.*

## EQUIPMENT CLEANING

Any device, hose, pipe, meter, valve, tank, pump, truck, etc. which has been used with recycled water may not be used to convey potable water nor attached to the potable water system unless it is cleaned and disinfected.

## MODIFICATIONS

The User must not make any modifications to its on-site recycled water system (or potable system, if it's in close proximity to the recycled system) without the prior approval of the Recycled Water Agency.

This includes modifications to the approved plans or to an operational system. Detailed plans of any modifications should be submitted to the Recycled Water Agency and the modifications inspected by the Recycled Water Agency before their being placed in operation.

However, routine maintenance of the irrigation system, such as pipeline repairs, sprinkler replacement and other similar activities that don't result in a substantial change in either the recycled or potable water systems, or any agreed to operating plans, don't need prior approval by the Recycled Water Agency.

Emergency modifications or repairs that must be made by the User to its system in order to prevent contamination, damage or a public health hazard are covered under *Emergency Procedures* (page 18).

## MAINTENANCE

The User must implement a preventive maintenance program that will ensure that the recycled water system always remains in compliance. A preventive maintenance program should include but not be limited to the following:

- ☞ Regular inspections should be conducted by the User of the entire recycled water system including sprinkler heads, spray patterns, piping and valves, pumps, storage facilities, lakes, controllers, signage, etc. Immediately correct any problems.
- ☞ All notification signs, labels and/or tags should be checked for their proper placement and readability. Replace damaged or unreadable signs, labels or tags.

- ☞ Special attention should be given to spray patterns to eliminate ponding, runoff and wind blown spray conditions.
- ☞ Establish and maintain an accurate records-keeping system of all inspections, modifications and repairs.
- ☞ Broken sprinkler heads, faulty spray patterns, leaking pipes or valves, etc. must be repaired when the malfunction becomes apparent.
- ☞ A maintenance program for backflow prevention assemblies that includes at least annual testing by a tester certified by the American Backflow Prevention Association (ABPA) or AWWA must be carried out. Records of annual tests, repairs and overhauls must be kept by the user with copies forwarded to the Recycled Water Agency and the local city or county Health Department.

## PERIODIC SITE INSPECTIONS

Periodic site inspections of the User's recycled water irrigation system are mandated in the Water Code (Section 13523.1(b)(5)). Such inspections include, at a minimum, the visual inspection of all back-flow prevention devices, pump rooms, exposed piping, valves, pressure reducing stations, points of connection, sprinklers, controllers, lakes, storage facilities, signs, labeling, tags, etc. The Site Supervisor's maintenance records should also be inspected.

These inspections are the responsibility of the entity holding the master water recycling permit issued by the Regional Board. This may be the Recycled Water Agency or the Recycled Water Producer, if separate. Whoever the responsible agency is may perform this inspection, or it may be delegated to a third party. The responsible

agency will also determine the frequency of these inspections, based on local conditions. The Recycled Water Agency also reserves the right to make unannounced inspections of the use site's facilities, although at reasonable times.

Upon completion of the inspection, a Site Inspection Report Form (see example, page 34) should be signed and dated by both the Site Supervisor and the entity performing the inspection. The original form should be kept by the inspecting entity with copies going to the Site Supervisor, the Recycled Water Agency and/or Producer and any required regulatory agency.

Should a cross-connection be discovered during the inspection, the *Emergency Cross-Connection Response Plan* (page 27) should be immediately invoked by the Site Supervisor.

## EMERGENCY PROCEDURES

In case of a major earthquake, the Site Supervisor should immediately inspect the potable and recycled water systems for damage. If either system appears damaged, both water systems should be shut off at their points of connection. The Site Supervisor should immediately contact the Recycled Water Agency for further instructions.

### Emergency Modifications

Emergency modifications or repairs can be made by the User to the recycled water system without the prior approval of the Recycled Water Agency to prevent contamination, damage or a public health hazard. As soon as possible the User must notify the Recycled Water Agency of the emergency modifications and file a written report.

### Unauthorized Discharge

It's the responsibility of the User to report to the Recycled Water Agency all system failures that result in an unauthorized discharge of more than 50,000 gallons of tertiary treated recycled water (or 1,000 gallons for any lesser quality recycled water). An immediate oral report followed by a written report is required.

### Contamination of Drinking Water

In case of contamination of the potable water system due to a cross-connection on the User's premises, the Recycled Water Agency and the local city or county Health Department must be immediately notified by the User (see page 36). The User is to immediately invoke the *Emergency Cross-Connection Response Plan*.

## VIOLATIONS

The Recycled Water Agency reserves the right to decide if a violation of the conditions under which the User Agreement was issued has occurred. Violations may include non-compliance of any of the following prohibitions: runoff conditions, ponding conditions, windblown spray conditions, leaks or spills resulting from broken or damaged pipelines or appurtenances, unapproved uses, disposal in unapproved areas, cross-connections, unprotected drinking fountains and unauthorized or prohibited use of hose bibbs, whether willful or by accident. Any willful or accidental act of noncompliance with any existing Federal, state or local ordinance, code, law or statute regulating the use of recycled water constitutes a violation.

## NOTIFICATION

It is the responsibility of the Site Supervisor to immediately notify the Recycled Water Agency of any failure or cross-connection in

his/her recycled or potable water system, whether or not he/she believes a violation has occurred. It is also the responsibility of the Site Supervisor to immediately notify the Recycled Water Agency of any violation he/she believes might imminently occur because of any action the User's personnel might take during the operation of the recycled or potable water systems.

If there are any doubts whether a violation has occurred, it is the responsibility of the Site Supervisor to report each occurrence to the Recycled Water Agency so a decision can be made. It is then the Recycled Water Agency's responsibility to notify the Recycled Water Producer (if a separate entity) holding the master water recycling permit from the Regional Board and local governing agencies of any violations. These agencies are listed in Section H.

### **CORRECTIVE ACTION**

If the Recycled Water Agency's investigation reveals that a violation has occurred on the reuse site, that agency must immediately notify the User of the violation and what corrective actions must be taken. It is the responsibility of the User to immediately initiate corrective action to eliminate the violation. If the Recycled Water Agency believes the violation constitutes a hazard to the public health, the Recycled Water Agency must immediately stop recycled water service to the User. It will be at the discretion of the Recycled Water Agency to decide if a violation has been adequately corrected.

The Recycled Water Agency may impose a startup fee upon resumption of service to a User whose service has been terminated, depending on the provisions of the User Agreement.

### **ENFORCEMENT**

The Recycled Water Agency shall enforce all existing regulations concerning the use of recycled water and/or recycled water systems. Regulations concerning the use of any recycled water or recycled water system shall be applied with equal force and effect to any person, persons, or firm, public or private. **There will be no deviations from these regulations** except upon written authorization of the Recycled Water Agency, acting within applicable regulations. An appeal procedure may be provided for in the User Agreement or in the Recycled Water Agency's rules and regulations, and the action of the Recycled Water Agency will be final.

### **CAUSES FOR TERMINATION OF SERVICE**

The Recycled Water Agency reserves the right to revoke a User's Agreement if any or all of the service conditions are not satisfied at all times. Service to a User may be terminated any time if:

- ☞ The Recycled Water Agency's distribution system is not capable of supplying recycled water.
- ☞ The quality of the recycled water does not comply with the requirements of the Regulatory Agencies.
- ☞ The User's operation does not conform to all applicable regulations, permit requirements and/or the terms of the User's agreement.
- ☞ There is nonpayment of service fees and charges by the User.



## SECTION D MARKING & EQUIPMENT

### GENERAL

All materials, apparatus, piping, valves, controllers, sprinkler heads, pumps etc. for new recycled water irrigation systems must be approved for use in a pressurized recycled water system and installed according to approved plans. The recycled water system must conform to the AWWA California-Nevada Section's Guidelines for the On-site Retrofit of Facilities Using Disinfected Tertiary Recycled Water. Deviations will not be allowed without prior approval. System installation must conform to the Uniform Plumbing Code and all other local codes, rules and regulations.

The approved use area must be clearly marked. All outlets from the recycled water system must be marked "**CAUTION -- RECYCLED WATER -- DO NOT DRINK.**" In addition, signs must be posted at all entrances to the use site indicating that recycled water is used for irrigation purposes. The "Do Not Drink" symbol (page 25) must be present on all signs. Recycled Water Agencies may also choose to require the signs to include translations into the appropriate foreign language(s), as not all areas have Spanish as the second language.

### PIPING, BELOW-GRADE

All new piping must be installed according to the approved plans and marked as required. Installation must be in accordance with the latest edition of International Association of Plumbing and Mechanical Officials (IAPMO) Standard IS-8. Fittings, primers and solvents must be IAPMO listed. All new recycled and potable water lines (pressure/non-pressure), new and existing valve boxes and appurtenances must be

identified to clearly distinguish between recycled water and potable water systems.

### Identification of Recycled Water Lines

All new, buried recycled water lines (pressure/non-pressure) must be extruded purple-colored Schedule 40 (minimum) PVC pipe with continuous wording "**CAUTION -- RECYCLED WATER**" printed on opposite sides of the pipe. The use of continuous lettering on 3-inch minimum width purple tape with 1-inch black or white contrasting lettering bearing the continuous wording "**CAUTION -- RECYCLED WATER**" permanently affixed at 10-foot intervals atop all horizontal piping, laterals and mains is an acceptable alternative to the purple pipe. Identification tape must extend to all valve boxes and/or vaults and exposed piping.



*Recycled water pipeline installation with continuous purple warning tape.*

Piping buried under pavement must be sleeved with the sleeve being at least two (2) inches larger in diameter than the irrigation pipe.

When recycled and potable water lines cross, the recycled water line must be located at least 1-foot below the potable water line. If this separation is not possible, then either the recycled or potable water line must be sleeved to 10 feet on either side of the crossover. Parallel recycled and potable water lines must be at least 10 feet apart, or at least 4 feet, if the recycled line is enclosed in a sleeve.

#### **Identification of Potable Water Lines**

New buried potable lines must be identified by continuous lettering on 3-inch minimum width blue tape with 1-inch white lettering bearing the continuous wording **“POTABLE WATER”** permanently affixed at 10-foot intervals atop all horizontal piping, laterals and mains. Identification tape must extend to all valve boxes, vaults and exposed piping.

Identification tape is not necessary for extruded blue-colored PVC with continuous wording **“POTABLE WATER”** printed in contrasting lettering on opposite sides of the pipe.

#### **Identification of Non-Potable Water Lines**

Non-potable water is water supplied from the potable water system through an appropriate backflow preventer. All non-potable irrigation/industrial water lines (pressure/non-pressure) must be identified by continuous lettering on 3-inch minimum width yellow tape with 1-inch contrasting lettering bearing the continuous wording **“NON-POTABLE WATER -- DO NOT DRINK”** permanently affixed at 10 foot intervals atop all horizontal piping, laterals and mains. Identification tape must extend to all valve boxes and/or vaults, exposed piping, hydrants and quick couplers.

#### **Identification of Existing Below-Grade Water Lines**

Existing below-grade piping, whether recycled, potable or non-potable, need not be marked unless the piping becomes exposed, such as during installation of new pipe or maintenance of existing pipe. The exposed section should be appropriately marked (as recycled, potable or non-potable) to the extent feasible.

#### **PIPING, ETC., ABOVE-GRADE**

All above-grade recycled water pipelines must be appropriately labeled and color-coded purple to differentiate recycled water pipelines from potable and non-potable water pipelines. If purple pipe is not used, recycled water pipelines may be wrapped with purple warning tape having the words **“CAUTION -- RECYCLED WATER”** visible in contrasting black letters. Flexible conduits or hoses must be clearly marked **“CAUTION -- RECYCLED WATER”** with each adapter or fitting painted purple.

Above-grade potable water pipelines must be labeled and color-coded blue to differentiate potable water pipelines from recycled and non-potable water pipelines. Potable water pipelines may be wrapped with blue identification tape having the words **“POTABLE WATER”** visible in contrasting white letters.

Above-grade non-potable water pipelines must be appropriately labeled and color-coded yellow to differentiate non-potable water lines from recycled water and potable water lines. Non-potable water lines may be wrapped with yellow identification tape having the words **“NON-POTABLE WATER -- DO NOT DRINK”** visible in contrasting letters.

Exposed valve boxes, vaults, quick coupling valves, outlets and related appurtenances must be color-coded, labeled or tagged, to differentiate recycled water from potable water (that is, “**CAUTION -- RECYCLED WATER -- DO NOT DRINK**” in black or white contrasting lettering on a purple background, or “**POTABLE WATER**” in white lettering on a blue background or “**NON-POTABLE WATER -- DO NOT DRINK**” in contrasting lettering on a yellow background).

Tags must be identified with the appropriate wording on both sides. Tags identifying recycled water must have both the appropriate wording and the “Do Not Drink” symbol (page 26).

## VALVES

### Quick Coupling Valves

New quick coupling valves, made specifically for recycled water use, should be 3/4-inch or 1-inch nominal size and of brass construction with a normal working pressure of 150 psi. The covers on all new quick coupling valves must be permanently attached and made of purple rubber or vinyl with the words “**RECYCLED WATER**” imprinted on the cover, and must be provided with a lock. To prevent unauthorized use, the valve should be operated only with a special coupler key with an acme thread for opening and closing the valve. New quick coupling valves should be installed approximately 12 inches from walks, curbs, headboards or paved areas. All new and existing quick coupling valves must be identified with an identification tag and installed in a marked valve box.



Quick coupler and valve box

### Gate Valves

New gate valves should be installed in a marked valve box with crushed rock in the base and a notification tag on the valve operator.

### Remote Control Valves

New and existing remote control valves should be installed in a marked valve box with crushed rock in the base and an identification tag on the operator. For each valve system, remote control valves should be adjusted so the most remote sprinkler heads operate at the pressure recommended by the manufacturer giving a uniform distribution of water.

## SPRINKLER HEADS

New sprinkler heads must be of the size, type, pressure, radius of throw and discharge as indicated on the approved plans. All new sprinkler heads, either permanent or temporary, should be of the approved type for use with recycled water and create the minimum amount of mist. Drainage through sprinkler heads is prohibited, and an anti-drain valve must be installed in the sprinkler riser as needed. Anchors on sprinkler risers should be provided as needed and maintained. Sprinkler heads must be kept in good repair at all times.

## SYSTEM CONTROL DEVICES

New system controllers must be automatic with multiple start/stop times for any 24-hour period and installed according to the approved plans and local codes. Two, color-coded diagrams must be prepared for the station and system for each controller. Each diagram should be sealed in plastic with one copy placed in the controller box and the other given to the Recycled Water Agency. All controllers must be marked with the words "**RECYCLED WATER**" in black 1-inch high letters on a purple background.

## STORAGE TANKS & IMPOUNDMENTS

All storage tanks, either stationary or portable, must be structurally sound and free from leaks. Each tank must be conspicuously marked with signs with the words "**RECYCLED WATER -- DO NOT DRINK**" in black letters 2-inches high on a purple background. The "Do Not Drink" symbol (page 25) should be present on all recycled water storage tanks.

Impoundments (lakes) that receive recycled water are classified as "unrestricted" (swimming and body contact allowed), "restricted" (no swimming or body contact, but non-contact activities such as fishing and boating allowed) or "ornamental" (no recreational activities allowed). All of these impoundments must have the recycled water valves and outlets marked or tagged with the words "**RECYCLED WATER -- DO NOT DRINK.**" At restricted and ornamental impoundments, adequate measures must be taken to prevent body contact. All recycled water impoundments must be kept separate from potable water wells and reservoirs.

If any storage tank or impoundment receives both recycled and potable water, the potable water supply must be properly air-gapped to avoid a cross-connection.

## OTHER DEVICES

All air/vacuum relief valves, valves, pressure reducing valves, pumps, pump control valves, etc., must be tagged or labeled indicating whether it is on the recycled water, non-potable water or potable water system. Recycled water tags or labels must have a purple background with black lettering stating "**RECYCLED WATER -- DO NOT DRINK.**" The "Do Not Drink" symbol (page 25) must be present.

Potable water tags or labels must have a blue background with "**POTABLE WATER**" in white lettering.

Non-potable water tags or labels must have a yellow background with "**NON-POTABLE**" in black lettering.

## VEHICLE IDENTIFICATION

Any vehicle used to transport recycled water must be clearly marked with labels or signs that contain the words "**RECYCLED WATER -- DO NOT DRINK**" in black 2-inch high letters on a purple background and include the "Do Not Drink" symbol (page 25). One label or sign should be placed on the tank closest to the driver's door, with a second label or sign being placed on the rear surface of the tank at the outlet. All labels and signs must be placed where they can easily be seen by the personnel using the vehicle.

Any vehicle used for the transportation or storage of recycled water must not be reused for the transportation or storage of potable water, unless it has been flushed, disinfected and tested.

### POSTING APPROVED USE AREA

Posting the use of recycled water is required at all entrances to the User's facility, and placed where they can be easily seen. The signs must indicate that "**RECYCLED WATER**" is in use. In addition, all signs must include the "Do Not Drink" symbol (page 25) and use the words "do not drink," in both English and Spanish (or other locally used language). Additional signing may be required by the Regulatory Agency on a case-by-case basis.



*Recycled water notification signs do not need to include such words as "Caution," "Warning" or "Danger."*

**“DO NOT DRINK” SYMBOL**



## SECTION E CROSS-CONNECTION CONTROL

### PROTECTION OF POTABLE WATER SYSTEMS

On “dual source” sites where both potable water and recycled water exist, the potable supply must be protected against accidental cross-connections. In lieu of an air-gap, reduced-pressure principal backflow prevention (RP) devices are generally approved by the State DHS and the Recycled Water Agency. This is done according to the approved site-specific drawings.

Backflow prevention devices must be approved by the Recycled Water Agency and the appropriate regulatory agencies before installation. If an RP is installed, it must be tested annually. The device testing must be done by a backflow prevention device tester certified by the ABPA or the AWWA. Test reports must be provided to the Recycled Water Agency and the regulatory agency requiring the test. Records must be maintained for at least three (3) years by both the User and the Recycled Water Agency.

### INITIAL CROSS-CONNECTION TEST

Prior to retrofit work or construction, a initial cross-connection inspection and test must be coordinated by the Recycled Water Agency, with all appropriate health agencies being notified. This test should follow the general guidelines outlined in Section F. The purpose of the test is to determine if there are any connections between the existing irrigation system and the potable water system prior to construction.

During the lifetime of the recycled water system, the Recycled Water Agency must periodically inspect the recycled water system to ensure compliance with all applicable rules and regulations. Additionally, the Recycled Water Agency may be required to perform periodic inspections of the system for cross-connections (including shut-down tests, if appropriate), depending on the use site characteristics.

### FINAL CROSS-CONNECTION TEST

On sites where both recycled and potable water are present, a cross-connection test must be performed using potable water supplied through an approved backflow prevention device before connecting the User's on-site recycled water system to the Recycled Water Agency's distribution system. This on-site test is to ensure the absolute separation of the recycled and potable water systems. The Recycled Water Agency shall coordinate the scheduling of the cross-connection test. Periodic testing using the same procedures may be required in the future, depending on the use site's characteristics. A written report documenting the test results must be submitted to the Recycled Water Agency, the State DHS and the local city or county Health Department following completion. A pressure (shut down) test procedure is detailed in Section F.

As an alternative to the pressure test, a dye test may be performed by charging the recycled water system with potable water containing a food grade colored dye. The unpressurized potable water system is then checked for any evidence of the colored dye. If the dye is found, a cross-connection

exists. This test itself must be done in a way that does not create a cross-connection.

Upon the successful completion of one of the above tests, insuring no cross-connections between the potable and recycled water systems, the User's irrigation system may be connected by the Recycled Water Agency to the recycled water distribution system.

### **PERIODIC CROSS-CONNECTION TESTING (PCCT)**

Periodic cross-connection shutdown testing must be done at least once every four (4) years for "dual-plumbed" sites, unless visual inspections or major on-site water system changes reveal a need for more frequent testing. The Water Recycling Criteria in Title 22 specifically defines "dual-plumbed" sites as either buildings with fixtures served with recycled and potable water or individual residences with recycled water in the irrigation system.

Other "dual-source" use sites that don't fall under either of these categories may be required to perform periodic cross-connection tests if the use site characteristics indicate a greater risk of potential cross-connections, or if any reuse site undergoes significant modifications of the potable or recycled water systems. The Recycled Water Agency, in cooperation with the local city or county Health Department, will make the determination if such a test is required.

This test must follow the same procedures use for the final cross-connection test (either shut-down or dye test). Before the test is performed representatives of the State DHS, the local city or county Health Department, Site Supervisor, Recycled Water Agency, and any other required

regulatory agency must be notified. The Recycled Water Agency will coordinate the scheduling of the test. A sample Test Notification Form is on page 36.

Written verification of the test results must be provided by the Recycled Water Agency to the Site Supervisor, State DHS, local city or county Health Department, local building authority and any other required regulatory agency. All provisions of Title 17, Chapter 5, Section 7601 of the Code of Regulations, concerning protection of drinking water systems against cross-connections and backflow, must be strictly complied with.

### **EMERGENCY CROSS-CONNECTION RESPONSE PLAN**

In the event that a backflow incident or cross-connection is suspected or occurs the following procedures must be implemented immediately.

1. Keep the potable water system pressurized and, if possible, post "**DO NOT DRINK**" signs at all potable water fixtures and outlets.
2. Immediately shut down the recycled water supply to the facility at the meter.
3. Notify the Recycled Water Agency and the appropriate Health Department(s) by phone (see list on page 37). This notification is to be followed by a written notice within 24 hours. The written notice is to include an explanation of the nature of the cross-connection, date and time discovered, and the steps taken to mitigate the cross-connection(s).



4. Collect water samples from the potable water system and perform a 24-hour bacteriological analysis (as instructed by the Recycled Water Agency). Water samples should be collected from the closest possible point to the cross-connection.
5. Identify the cause and location(s) of backflow and eliminate the cross-connection(s).
6. Conduct a cross-connection test in coordination with the Recycled Water Agency and the appropriate Health Departments to verify that all cross-connections have been eliminated.
7. Obtain approval from the Recycled Water Agency and the local city or county Health Department before returning the recycled water system to service.
8. If the bacteriological analysis conducted in Step 4 is positive, flush the potable water system and disinfect by maintaining a chlorine residual of at least 50 mg/L for 24 hours. Otherwise proceed to Step 11.
9. Flush the potable water system after 24 hours and perform standard bacteriological analysis.
10. If the results from Step 9 are acceptable, proceed to Step 11. Otherwise, repeat Steps 8-9.
11. Obtain final approval from the Recycled Water Agency and the State, local city or county Health Department before removing signs.

## SECTION F REUSE SITE PRESSURE-TESTING PROCEDURE

The following are general guidelines for the testing procedure and may be modified with the approval of the State, local city or county Health Department.

1. Potable water must be used during the initial testing of the on-site recycled water system, with the potable water supply separated from the proposed recycled water system by an approved reduced pressure principle backflow prevention assembly until the system has been checked for cross-connections.
2. The recycled water system should be completely drained and remain deactivated for an adequate period of time based on site-specific characteristics.
3. At the end of the shutdown period, all of the recycled water outlets should be tested throughout the entire site for cross-connections by checking each outlet for flow.
4. The recycled water system should then be checked at the quick couplers (located on the normally pressurized main irrigation line) or by cycling the irrigation clocks (observing the spray decrease) to determine if there is any flow. If there is no flow detected in any of the outlets that would suggest a cross-connection, the recycled water connection may then be reactivated.
5. The potable water to the use site will be shut off at the potable water meter. The potable water system must be completely drained and remain deactivated for an adequate period of time based on site-specific characteristics.
6. At the end of the shutdown period, all of the use site's potable water fixtures should be tested for cross-connections by operating each fixture and checking for flow.
7. The potable water inlet should then be checked to detect if there is backpressure or significant backflow. If no flow is detected at the inlet or in any of the fixtures that would suggest a cross-connection, the potable water connection may then be reactivated.

## SECTION G SAMPLE FORMS AND SITE SPECIFIC DETAILS

### SUMMARY OF STEPS TO OBTAIN RECYCLED WATER

**NOTE: The following sequence of events is general in nature and is for illustration only. Please check with your Recycled Water Agency for the appropriate process.**

Potential User contacts the Recycled Water Agency for recycled water service, and the Agency responds in a timely manner.

Potential User must have irrigation plans stamped by a registered landscape architect or a registered civil engineer.

Potential User submits a recycled water application (an example is shown on page 33) and pays the application fee. The User agreement is explained and signed at this time.

The potential User shall apply to the Recycled Water Agency for a recycled water meter. A construction meter for potable water and an appropriate backflow prevention device may be required for temporary water and system testing before being served recycled water.

Recycled Water Agency notifies the State, local city or county Health Department of the submitted application.

Potential User submits two sets of plans each to the Recycled Water Agency and to either State DHS or the local city or county Health Department for plan check, and pays the applicable plan check fees.

Recycled Water Agency, State DHS, and the local city or county Health Department complete plan check and return plans to the potential User for corrections.

After all corrections are made the potential User resubmits the marked plan checked prints along with a final set of plans. If no more corrections are to be made, the Recycled Water Agency, State DHS, and the local city or county Health Department will approve the original plans. Four (4) sets of prints of the signed plans each should be submitted to these agencies.

A pre-job meeting (preliminary inspection) is held before construction with the Recycled Water Agency's representative, potential User and the contractor. This meeting is to cover the plan's general notes, specific job requirements and cover any questions. Following this meeting, an initial cross-connection test is to be conducted on existing systems with the state and/or city or county health agencies.

The potential User may begin construction, according to the approved plans, contingent upon any other required permits or approvals being obtained. Approvals for deviations in the approved plans are to be sought as they occur.

All work during construction must be inspected by the Recycled Water Agency and/or the local city or county Health Department **before** backfilling any buried piping. If any reclaimed or potable water piping is installed before plan check approval and/or inspection, all or any portion of the piping system may be required to be exposed and corrected as necessary.

After construction is completed, the Recycled Water Agency and either State DHS or the local city or county Health Department must be notified for the final inspection and cross-connection test utilizing potable water supplied through an approved backflow prevention device on dual source sites. The recycled water meter is installed, potable water severed and conversion made to recycled water. During this walk through flow adjustments are made, tagging is inspected, and coverage is checked. A thorough cross-connection test is conducted at this time to verify that construction was performed correctly. The Recycled Water Agency and/or the local city or county Health Department will generate a punch list of corrections to be made if necessary.

A follow-up walk through will be called for after all corrections from the first walk-through are completed if required. This walk-through will inspect to see that all corrections are complete, including color-coded plans for each controller that are accurate and placed at each controller cabinet. Upon the successful completion of the inspection and cross-connection tests, the User will be granted permission for the normal operation of the system. At this time the Recycled Water Agency's inspector will discuss with the User and the User's Site Supervisor conditions for operation, inspections etc.

**LOCAL CONTACTS**

**SITE:**

---

**LOCATION:**

---

**SUPERVISOR:**

---

**PHONE:**

---

**RECYCLED WATER AGENCY CONTACTS**

**WATER OPERATIONS:**

---

**PHONE:**

---

**SUPERVISOR:**

---

**PHONE:**

---

**RECYCLED WATER INSPECTOR:**

---

**PHONE:**

---

**RECYCLED WATER AGENCY'S ENGINEER:**

---

**PHONE:**

---

**RECYCLED WATER IRRIGATION**  
**USER APPLICATION**

Today's Date: \_\_\_\_\_  
Tract No. \_\_\_\_\_ Project Name: \_\_\_\_\_  
Location: \_\_\_\_\_ or Brief Legal Description: \_\_\_\_\_

---

Type of Development: \_\_\_\_\_

Description of proposed uses of recycled water: \_\_\_\_\_

Expected date to commence recycled water service (Month/Year) \_\_\_\_\_  
Estimated Water Requirements:

	<u>Acres</u>	<u>Average AF/YR</u>	<u>Peak Demand (GPM)</u>
Landscape Irrigation:	_____	_____	_____
Park:	_____	_____	_____
Open Space:	_____	_____	_____
School:	_____	_____	_____

Owner: _____	Engineer: _____
Address: _____	Address: _____
City: _____	City: _____
State: _____ Zip: _____	State: _____ Zip: _____
Phone: (____) _____	Phone: (____) _____
Contact: _____	Contact: _____

**RECYCLED WATER - SITE INSPECTION REPORT**

Site: \_\_\_\_\_ Date: \_\_\_\_\_

Inspected By:

Title: \_\_\_\_\_ Agency: \_\_\_\_\_

<b>AREA INSPECTED</b>	<b>NO</b>	<b>YES</b>
- PIPING -		
Piping properly marked?	___	___
Valves etc. properly marked?	___	___
Has piping been modified?	___	___
If yes, are modifications approved?	___	___
Points of connection properly marked?	___	___
Piping System "Leak"?	___	___
- SIGNING -		
Are all signs properly placed?	___	___
Are all signs legible?	___	___
Are tags visible and legible?	___	___
- BACKFLOW PREVENTION -		
Backflow Prevention Device installed?	___	___
Does the device appear damaged?	___	___
Is the device leaking?	___	___
Is the device unobstructed?	___	___
Is Recycled Water being used for its approved purpose?	___	___

Comments: \_\_\_\_\_

Signed: \_\_\_\_\_ Date: \_\_\_\_\_

**CROSS-CONNECTION TEST NOTIFICATION FORM**

Test Date: \_\_\_\_\_ Test Time: \_\_\_\_\_

Site Name: \_\_\_\_\_

Site Address: \_\_\_\_\_

\_\_\_\_\_

Recycled Water Agency:

\_\_\_\_\_

Contact Person: \_\_\_\_\_ Phone: \_\_\_\_\_

Agencies Notified: California Department of Health Services, Drinking Water Field  
Operations Branch

\_\_\_\_\_

\_\_\_\_\_

\_\_\_\_\_

**CROSS-CONNECTION NOTIFICATION RSVP FORM**

Site Address: \_\_\_\_\_

\_\_\_\_\_

Test Date: \_\_\_\_\_

Agency/Company: \_\_\_\_\_

Representatives Attending: \_\_\_\_\_

\_\_\_\_\_

(Please return to requesting party within 10 days of scheduled test)



## SECTION F LOCAL GOVERNING AGENCIES

*(Local Recycled Water Agency to insert own name, address, phone number, and modify contact information below for its own region)*

### **Regional Water Quality Control Board**

Los Angeles Region  
320 W. 4th Street, Suite 200  
Los Angeles, CA 90013  
(213) 576-6600

### **County of Los Angeles Department of Health Services**

Cross Connection and Water Pollution Control  
5050 Commerce Drive  
Baldwin Park, CA 91706  
(626) 430-5290

### **State of California Department of Health Services**

Drinking Water Field Operations Branch  
1449 West Temple Street  
Los Angeles, CA 90026  
(213) 580-5723

## SECTION G DEFINITIONS

Whenever the following terms, or pronouns used in their place, occur in this Manual the intent and meaning shall be interpreted as follows:

**Air Gap Separation** – A physical break between a water line and a receiving tank or reservoir which is at least double the diameter of the pipeline vertically above the rim of the tank or reservoir, and in no case less than one-inch.

**Applicant** – An Owner or authorized representative of a potential reuse site who applies for recycled water service under terms of the appropriate regulations. An approved Applicant becomes a User.

**Approved Backflow Prevention Assembly** – A device installed to protect the potable water supply from contamination by nonpotable water and is approved by the State of California.

**Approved Use** – An application of recycled water in a manner, and for a purpose, designed in a user agreement issued by the Recycled Water Agency and in compliance with all applicable Regulatory Agency requirements.

**Approved Use Area** – A site with well-defined boundaries, designated in a user agreement issued by the Recycled Water Agency to receive recycled water for an approved use and acknowledged by all applicable Regulatory Agencies.

**Chief Executive Officer** – The highest-ranking management official of the Recycled Water Agency.

**Construction Use** – An approved use of recycled water to support approved construction activities, such as soil compaction and dust control during grading.

**Cross-Connection** – Any physical connection between any part of a water system used or intended to supply water for drinking purposes and any source or system containing water or substance that is not or cannot be approved as safe, wholesome and potable for human consumption.

**Graywater** – Untreated domestic wastewater from bathtubs, showers, bathroom wash basins, clothes washing machines, and laundry tubs, but excluding toilets, kitchen sinks, dishwashers, photo development sinks and laundry water from soiled diapers. This is **not** the same as treated recycled water.

**Infiltration Rate** – The rate at which the soil will accept water as applied during irrigation, expressed in inches per hour.

**Inspector** – Any person authorized by the Recycled Water Agency or the local health agencies to perform inspections on or off the Users site before construction, during construction, after construction and during operation.

**Irrigation Period** – The time, from start of water flow to end, which a specific area receives recycled water by direct irrigation application, no matter how often the specific area is irrigated - that is length of the duty cycle.

**Irrigation Use** – An approved use of recycled water for landscape irrigation as defined for recycled water under Title 22, Chapter 3 of the California Code of Regulations.

**Landscape Impoundment** – An open body of recycled water on a use site that is utilized for aesthetic enjoyment or which otherwise serves a function not intended to include public contact.

**Local City or County Health Department** – This agency is the local health protection agency for the municipality in question.

**Nonpotable Water** – The water that has not been treated for human consumption in conformance with the latest edition of the United States Environmental Protection Agency's Drinking Water Standards, the California Safe Drinking Water Act, or any other applicable standards. This also refers to irrigation or industrial process water derived from a potable water system through an approved backflow prevention device that may be subject to contamination (e.g., through back-siphonage).

**Off-site** – Designates or relates to recycled water facilities up to and including the water meter that are owned and operated by the Recycled Water Agency.

**On-site** – Designates or relates to facilities owned and operated by a User.

**Operations Personnel** – Any employee of a User, whether permanent or temporary, or any contracted worker whose regular or assigned work involves the supervision, operation or maintenance of equipment on any portion of on-site facilities using recycled water.

**Operator** – Any person, persons or firm, who by entering into an agreement with a User is responsible for operating on-site facilities.

**Owner** – Any holder of legal title, contract purchaser, or lessee under a lease with an unexpired term of more than one (1) year, for property for which recycled water service has been requested or established.

**Point of Connection** – This is the point where the User's system ties to the Recycled Water Agency's system, usually at the water meter.

**Ponding** – Unintentional retention of recycled water on the surface of the ground or other natural or manmade surface for a period following the cessation of an approved recycled water use activity such that a hazard or potential hazard to the public health results.

**Potable Water** – That water that is pure and wholesome, does not endanger the lives or health of human beings, and conforms to the latest edition of the California Safe Drinking Water Act, or other applicable standards.

**Public** – Any person or persons at large who may come in contact with facilities and/or areas where recycled water is approved for use.

**Rate and Fee Schedule** – The schedule of all rates, charges, fees and assessments to be made concerning the use of recycled water served by the Recycled Water Agency as approved or as amended by the Recycled Water Agency.

Note: If the recycled water provided by an investor-owned utility functioning as the Recycled Water Agency, rates and fees are approved or amended by the California Public Utilities Commission.

**Recreational Impoundment** – An open body of recycled water located on a use site that may be used for unrestricted body contact (e.g., swimming, wading) or restricted non-body contact (e.g., boating, fishing) recreation.

**Recycled Water** – Nonpotable water that is highly treated to the California Code of Regulations, Title 22, Chapter 3 and used for approved purposes other than drinking water.

**Recycled Water Agency** – The local purveyor or producer of recycled water for the specified service area (public or private).

**Regulatory Agencies** – Those public agencies legally constituted to protect the public health and water quality, such as the State Department of Health Services, the California Regional Water Quality Control Board and the local city or county Health Department.

**Runoff** – When recycled water is intentionally or unintentionally allowed to drain outside the approved recycled water irrigation area.

**Service** – The furnishing of recycled water to a User through a metered connection to the on-site facilities.

**Site Supervisor** – A qualified person designated by the User to provide liaison with the Recycled Water Agency. This person should be available to the Recycled Water Agency at all times, should have the knowledge and authority to carry out any requirements of the Recycled Water Agency, and should be responsible for the installation, operation and maintenance of the reclaimed and potable water systems and also prevention of potential hazards.

**State Department of Health Services** – Shall be the State of California Department of Health Services, Drinking Water Field Operations Branch.

**Unauthorized Discharge** – Any release or spill of recycled water that violates the rules and regulations of the Recycled Water Agency or all applicable Federal, State or local statutes, regulations, ordinances, contracts or other requirements.

**User** – Any person, persons or organization (including, but not limited to, any private company or corporation, public utility, municipality or other public body or institution) issued a recycled water Users' Permit by the Recycled Water Agency. The User and Owner may be the same.

**User Agreement** – An agreement issued by the Recycled Water Agency to a recycled water service Applicant after the satisfactory completion of the service application procedures. This Agreement forms a service agreement between the User and the Recycled Water Agency that legally binds the User to all conditions stated in the Agreement and all applicable Regulatory Agency requirements.

**User Agreement (For Users Served by an Investor-Owned Utility)** – An agreement shall consist of the signed Application, the User Manual, a copy of the applicable Regional Water Quality Control Board water recycling permit and the California Public Utilities Commission approved Tariff Schedules. These form a service agreement between the User and the Recycled Water Agency that legally binds the User to all conditions stated in the Agreement and all applicable Regulatory Agency requirements.

**Violation** – Noncompliance with any condition or conditions of the User Agreement, water recycling requirements issued the Regional Water Quality Control Board and/or Title 22, Chapter 3 of the California Code of Regulations by any person, action or occurrence, whether willfully or by accident.

**Windblown Spray** – Dispersed, airborne particles of recycled water that can be transmitted through the air to locations other than those approved for the direct use of recycled water.

## SECTION H TIPS FOR SUCCESSFUL USAGE

The recycled water that is delivered for beneficial reuse has been “manufactured” at a water reclamation plant, resulting in a quality that meets very strict DHS standards for safety. Even though it is virtually impossible to distinguish the recycled water, as described in this Manual, from potable water supplies. However, there are general chemical differences that may require Users to make changes in their landscaping practices. The following few pages is not meant to be a comprehensive discussion of issues that might arise when irrigating with recycled water; but only the most common areas of concern.

### SALT LEVELS

Salt is a difficult and expensive constituent to remove from water; consequently, it and other minerals that are not often removed by conventional treatment processes. The salinity, or salt levels in recycled water can vary from treatment plant to treatment plant, but are generally higher than the local domestic water supply. Therefore, Users may want to carefully consider their selection of plants, soil composition and irrigation practices.

#### Type of Plants

For the most part, turf grass is very tolerant of higher salt levels, as are many ornamental trees and shrubs. Additionally, experience has shown that most flowering plants thrive with the use of recycled water.

However, not all landscape plants are suitable for irrigation with recycled water. Most notable of these are azaleas, which

are very salt **intolerant** and should be avoided when using recycled water.

#### Soil Types

The type of soil present at a User's site strongly influences how the salt in the recycled (or any) water affects plant growth and health. Well draining soil is preferable; however, many areas have a clay component in their soil. Clay tends to hold on to salt, and can actually cause the soil to stop draining altogether. This particular phenomenon is the direct result of elevated levels of sodium and is measured by its ratio to calcium and magnesium (Sodium Adsorption Ratio, or SAR). The presence of self-regenerating water softeners that discharge sodium-laden brine into the sewer system are big contributors to elevated sodium levels in the recycled water.

Problems with soil drainage due to clay soils and an elevated SAR can be rectified by the application of gypsum (calcium), which loosens the bound up clay and allows for water to drain through the soil.

However, when dealing with clay soil drainage issues, some recycled water users have rejected gypsum as it increases the salinity and instead opted for an acid injection system. Buffered acid can be added to break up the bicarbonate binding and salt buildup at the surface level in clay soils and allow improved penetration to the root zone.

#### Irrigation Schedule

Many irrigation systems schedule watering for short periods of time, perhaps many nights a week. Depending on the levels of salt in the recycled water

and the soil type (sand vs. clay), a switch to longer irrigation run times done on a less frequent basis may be called for. Short irrigation runs have the potential to deposit more salt in the root zone, with possible adverse impacts on plant health and growth. Clay soil is more susceptible to this phenomenon than better-draining soils. Heavier watering done less frequently leaches the accumulating salts out of the root zone.

This is particularly important in regions of the state that don't experience sufficient precipitation during the rainy season. Rainfall can have the same effect as longer watering periods, if the rainstorms are heavy enough. Periods of drought can exacerbate the build-up of salts further but can be answered with a modified irrigation schedule.

## NUTRIENTS

Recycled water may also contain higher nutrient levels such as nitrogen, phosphorous and potassium, which are essential components for plant growth. Some treatment processes may reduce the levels of these chemicals, although they are not totally removed.

### Fertilizer Value

While nutrient levels vary among treatment plants, there are sufficient levels of nitrogen, phosphorous and potassium in the recycled water to provide fertilizer value to the landscaping each and every time irrigation takes place. Based on nutrient levels in the recycled water being supplied, a Site Supervisor can readily calculate the number of pounds of each constituent being delivered. He or she can then determine how much, if any, and what kind of additional fertilizer needs to be applied.

A common mistake is to continue the same fertilizer application schedule that was in place when domestic water was being used for irrigation. The addition of applied fertilizer, on top of the extra nutrients in the recycled water, can cause problems with plant health, groundwater quality problems and avoidable costs to the site in buying and using unnecessary fertilizer.

### Ornamental Lakes

Some reuse sites have ornamental lakes as part of the landscaping. Care must be exercised if recycled water is used to supply these lakes. The nutrient value in the recycled water readily promotes the growth of algae, which can impair the aesthetics of these lakes. This is especially a problem in lakes that are less than 10 feet deep, due to sunlight penetration.

Several different strategies have been employed at such lakes, with the greatest level of success in algae control coming from combinations of two or more of the following methods.

- ☞ Pumping the recycled water from the lake into the irrigation system reduces the amount of time the water (and the nutrients it contains) spends in the lake, consequently reducing algae production.
- ☞ Re-circulating the water by means of fountains or waterfalls or installing more extensive aeration systems.
- ☞ Preventing the introduction of organic material (such as grass clippings) from entering the lake.

- ☞ Stocking the lake with algae eating fish, such as Tilapia (?). However, some fish, like koi, react unfavorably to the higher ammonia levels that may be in the recycled water.
- ☞ Using a chemical product, such as Aqua-Shade, to prevent sunlight from penetrating the water column.
- ☞ Using a chemical algaecide, such as copper sulfate. (Warning: This product is also toxic to other organisms, so the lake water could not be used for landscape irrigation.)
- ☞ Because refilling ornamental lakes may not be a significant consumptive use of the recycled water, in some cases it may be preferable to fill the lakes with potable water or even non-potable well water.

### **Increased Mowing**

Reports from many turf sites using recycled water have reported the need to mow their grass more often. This is the direct result of the additional nutrients in the recycled water being available for uptake by the grass.